

## Relative and differential pressure transmitter

-0.5 ... +0.5 mbar / 0 ... 1 – 50 mbar

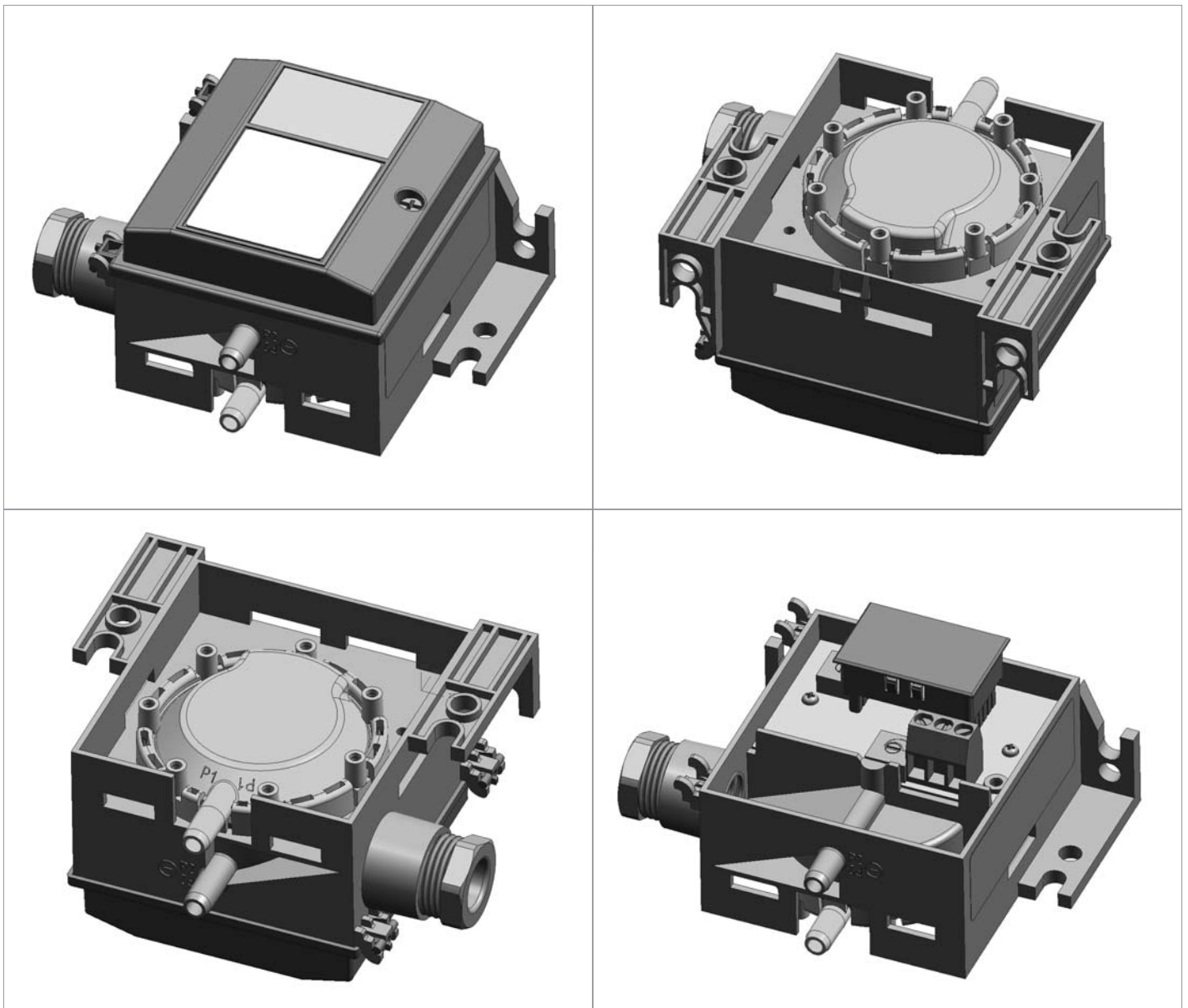

**Huba Control**

FEINE MESSIDEEN FÜR DRUCK UND STRÖMUNG  
FOR FINE PRESSURE AND FLOW MEASUREMENT  
LA FINESSE DES MESURES DE PRESSION ET DE DEBIT

## Technical overview

The differential pressure transmitters of the Type 694 series incorporate a proven ceramic fulcrum lever technology.

They deliver adjusted and temperature-compensated sensor signals, available as standard voltage or current outputs.

They are ideal for registering low air flow in air conditioning systems and for the measurement of fine pressures in laboratory, environmental and clean-room applications.

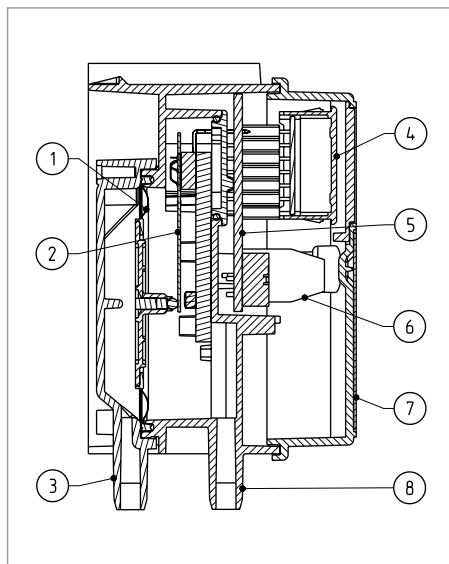

## Legend to cross-section drawing

- 1 Diaphragm
- 2 Sensor element
- 3 P1 Pressure connection (higher pressure)
- 4 Display (option)
- 5 Amplified electronics
- 6 Connection terminals
- 7 Cover
- 8 P2 Pressure connection (lower pressure)

## The distinct advantages

- Compact construction
- Fast, easy mounting.  
Housing incorporates integral bracket for wall or ceiling mounting. Snap-on cover with a single screw
- Available with or without LCD display
- Available with or without root-extracted output
- Available zero point and full scale adjustable
- Attractive price/performance ratio

## Medium

Air and neutral gases

## Pressure range

–0.5 ... +0.5 mbar / 0 ... 1 – 50 mbar  
 –50 ... +50 Pa / 0 ... 100 – 5000 Pa  
 –0.2 ... +0.2 inH<sub>2</sub>O / 0 ... 0.4 – 20 inH<sub>2</sub>O  
 –5 ... +5 mmWC / 0 ... 10 – 500 mmWC

## Tolerable overload on one side

100 mbar  
 10'000 Pa  
 40 inH<sub>2</sub>O  
 1000 mmWC

For ± type max.:

100 mbar on P1, 4 mbar on P2  
 10'000 Pa on P1, 400 Pa on P2  
 40 inH<sub>2</sub>O on P1, 1.6 inH<sub>2</sub>O on P2  
 1000 mmWC on P1, 40 mmWC on P2

## Rupture pressure

2 x overload at ambient temperature  
 1.5 x overload at 70 °C

## Setting range

Zero point ±10% fs  
 Full scale 40 ... 100% fs

## Materials in contact with medium

Housing: Polycarbonate PC  
 Diaphragm: Silicone  
 Sensor: Al<sub>2</sub>O<sub>3</sub> (96%) / glass

## Temperature

Medium and ambient 0 ... +70 °C  
 Storage –10 ... +70 °C

No condensation

## Output Power supply

3-wire  
 0 ... 10 V 13.5 ... 33 VDC / 24 VAC ±15%  
 0 ... 20 mA 13.5 ... 33 VDC / 24 VAC ±15%  
 4 ... 20 mA 13.5 ... 33 VDC / 24 VAC ±15%

2-wire  
 4 ... 20 mA 11.0 ... 33 VDC

## Load

3-wire  
 0 ... 10 V > 10 kOhm  
 0 ... 20 mA < 400 Ohm  
 4 ... 20 mA < 400 Ohm

2-wire  
 4 ... 20 mA  $< \frac{\text{supply voltage} - 11 \text{ V}}{0.02 \text{ A}}$  [Ohm]

## Current consumption

At nominal pressure

3-wire  
 0 ... 10 V < 10 mA  
 0 ... 20 mA < 30 mA  
 4 ... 20 mA < 30 mA  
 2-wire  
 4 ... 20 mA 20 mA

## Dynamic response

Suitable for dynamic measurements  
 Response time < 10 ms  
 Load cycle < 10 Hz

## Electrical connection

Screw terminals for wire and stranded conductors up to 1.5 mm<sup>2</sup>, cable gland with built-in strain relief PG11

## Polarity reversal protection

Short circuit proof and protected against polarity reversal. Each connection is protected against crossover up to max. supply voltage.

## Protection standard

Without cover IP 00  
 With cover IP 54  
 On request IP 65

## Pressure connections

Connection pipe Ø 6.2 mm

## Installation arrangement

Recommended and factory adjustment:  
 Vertical, with pressure connections downwards (± types forcible)

Horizontal with cover downwards.  
 Signal approximately 13 Pa higher than actual pressure

Horizontal with cover upwards.  
 Signal approximately 13 Pa lower than actual pressure

## Mounting

Mounting bracket (integrated in case)

## Display

Liquid-crystal, 3 digit

## Tests / Admissions

ETL  
 CE conform

## Weight

With display approx. 100 g  
 Without display approx. 90 g

## Packaging

Single packaging in cardboard

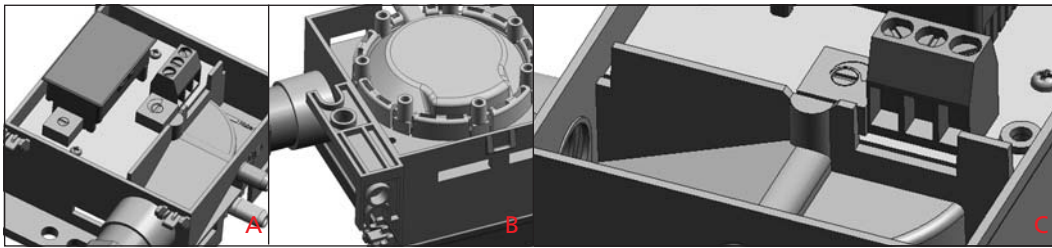

## Versions

- A – 2 potentiometers for full scale and zero point adjustment
- B – Housing with built-in fixing brackets
- C – Self-retaining screw in cover and angled surface for easy cable entry

## Accuracy

Transmitter Type Parameter	Unit	± 0.5 mbar	0 ... 1 mbar	0 ... 3 mbar	0 ... 5 mbar	0 ... 10–50 mbar
Tolerance zero point <sup>1)</sup>	max. % fs	± 1.0	± 1.0	± 0.7	± 0.7	± 0.7
Tolerance full scale <sup>1)</sup>	max. % fs	± 1.0	± 1.0	± 0.7	± 0.7	± 0.7
Resolution	% fs	0.2	0.2	0.1	0.1	0.1
Total of linearity, hysteresis and repeatability	max. % fs	± 3.0	± 2.0	± 1.0	± 1.0	± 0.6
Long term stability acc. to DIN IEC 60770	% fs	± 1.0	± 1.0	± 1.0	± 1.0	± 1.0
TC zero point <sup>2)</sup>	typ. % fs/10 K	± 0.2	± 0.2	± 0.2	± 0.1	± 0.1
TC zero point <sup>2)</sup>	max. % fs/10 K	± 1.0	± 1.0	± 0.5	± 0.4	± 0.4
TC sensitivity <sup>2)</sup>	typ. % fs/10 K	+ 0.3	+ 0.3	+ 0.2	+ 0.1	± 0.1
TC sensitivity <sup>2)</sup>	max. % fs/10 K	+ 0.6	+ 0.6	+ 0.5	+ 0.5	± 0.2

### With root-extracted output (2 ... 100% pressure)

Absolute error: (% of full scale)

TC zero point: (% fs) <sup>2)</sup>

–0.5 ... +0.5 mbar / 0 ... 1 mbar

$$\text{max. } \pm 0.6 \sqrt{\frac{P_{fs}}{P}} + 1.5$$

0 ... 3 – 50 mbar

$$\text{max. } \pm 0.3 \sqrt{\frac{P_{fs}}{P}} + 1.5$$

$$\text{max. } \pm 0.6 \sqrt{\frac{P_{fs}}{P}} + 1.5$$

Test conditions: 25 °C, 45% RH, Power supply 24 VDC  
TC z. p. / TC s. 0 ... 70 °C

## Order code selection table

694. 9 X X X X X X X X X X

Pressure range <sup>3)</sup>	mbar (hPa)	Pa	mmWC (mmH <sub>2</sub> O)	inH <sub>2</sub> O																
–0.5 ... +0.5	–50 ... +50	–5 ... +5	–0.2 ... +0.2		3	1														
0 ... 1	0 ... 100	0 ... 10	0 ... 0.4		1	1														
0 ... 3	0 ... 300	0 ... 30	0 ... 1.2		1	2														
0 ... 5	0 ... 500	0 ... 50	0 ... 2		1	3														
0 ... 10	0 ... 1000	0 ... 100	0 ... 4		1	4														
0 ... 16	0 ... 1600	0 ... 160	0 ... 6.4		1	5														
0 ... 25	0 ... 2500	0 ... 250	0 ... 10		1	6														
0 ... 50	0 ... 5000	0 ... 500	0 ... 20		1	7														
Unit of pressure	mbar (hPa)									0										
	Pa									2										
	mmWC (mmH <sub>2</sub> O)									3										
	inH <sub>2</sub> O									1										
Output signal / Adjustment	Linear												1							
	Linear	Full scale and zero point adjustable by customer											2							
	Square root extracted									1			4							
	Square root extracted	Full scale and zero point adjustable by customer								1			3							
Output <sup>4)</sup> and power supply	0 ... 10 V	13.5 ... 33 VDC / 24 VAC ±15%	3-wire										1							
	0 ... 20 mA	13.5 ... 33 VDC / 24 VAC ±15%	3-wire										3							
	4 ... 20 mA	13.5 ... 33 VDC / 24 VAC ±15%	3-wire										4							
	4 ... 20 mA	11.0 ... 33 VDC	2-wire										5							
Display 3 digit	Without																			0
	In pressure unit chosen above												1							1
	In % fs																			2
Pressure connections / Pressure orifices	Connection pipe Ø 6.2 mm	without pressure orifice																		1
	Connection pipe Ø 6.2 mm	pressure orifice on P1																		2
	Connection pipe Ø 6.2 mm	pressure orifice on P2																		3
	Connection pipe Ø 6.2 mm	pressure orifices on P1 and P2																		4
Connection kit	Without																			0
	With connection kit (metal), 90° angled	including tube 2 m long (Fig. 1) <sup>5)</sup>																		1
	With connection kit (plastic), straight	including tube 2 m long (Fig. 2) <sup>5)</sup>																		2
Pressure range variation	Indicate W and state pressure range on order																			W

## Accessories

	Order number
Connection kit for vent duct (metal), 90° angled including tube 2 m long (Fig. 1) <sup>5)</sup>	104312
Connection kit for vent duct (plastic), straight including tube 2 m long (Fig. 2) <sup>5)</sup>	100064
Calibration certificate	104551

1) For changing diaphragm position see installation arrangement page 6  
 2) TC = Temperature coefficient  
 3) Other pressure ranges on request  
 4) Other output signals on request  
 5) See page 8

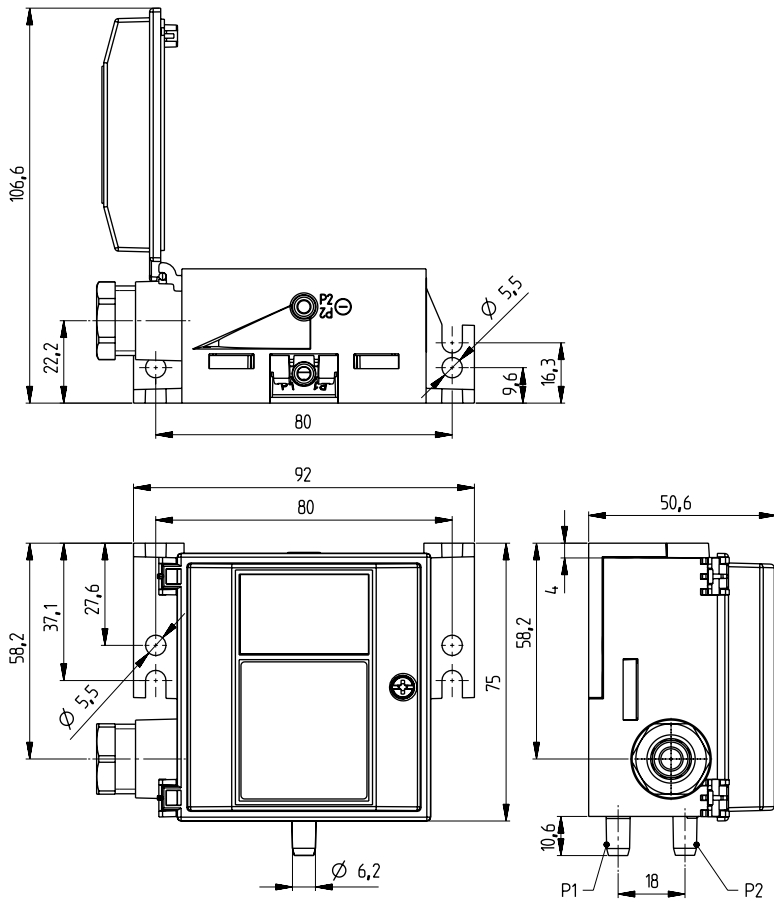

Root-extracted signal

$$[\%] = 100 \cdot \sqrt{\frac{p [\%]}{100}}$$

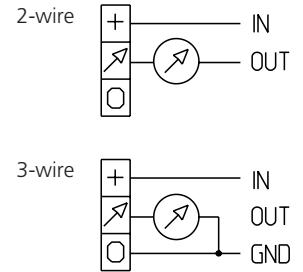
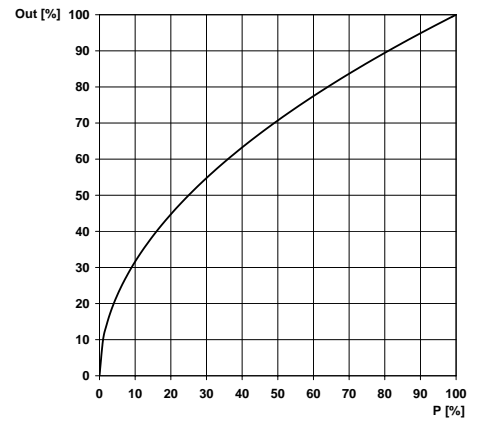

Accessories

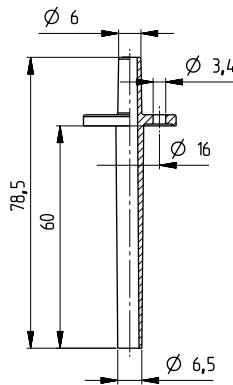
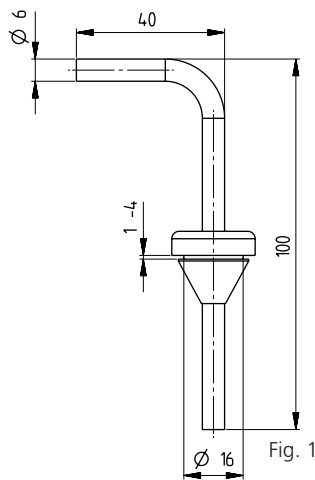

Electromagnetic compatibility

CE conformity (EMC) by application of harmonised standards: EN 61000-6-2, EN 61000-6-3 and EN 61326

Interference stability	Test standard	Effect
Electrostatic discharge (ESD)	EN 61000-4-2 8 kV air / 4 kV contact	no effect
High-frequency electromagnetic radiation (HF)	EN 61000-4-3 10 V/m, 80 ... 1000 MHz	no effect
Fast transients (burst)	EN 61000-4-4 ± 4 kV	no effect
Surge	EN 61000-4-5 Line-Line: ± 1 kV Line-Ground: ± 2 kV	no failure
Conducted HF interference	EN 61000-4-6 10 V, 0.15 ... 80 MHz	no effect
Magnetic fields	EN 61000-4-8 30 A/m, 50 Hz	no effect
Short time interruption and voltage fluctuation	EN 61000-4-11 60%	no effect
Interference emit	Test standard	Effect
Conducted interference	EN 55022 (CISPR 22) 0.15 ... 30 MHz	no emission
Radiation from housing	30 ... 1000 MHz, 10 m	no emission